

THREE-PHASE INDUCTION MOTOR

OUTPUT	TYPE	FORM	RATING	VOLTAGE (V)	FREQ. (Hz)	SYNC. SPEED (min ⁻¹)	POLES	INS. CLASS	MASS (kg)
1/2HP	VTFO	K	S1	220/380	50	3000	2	F	10.5
1/2HP	VTFO	K	S1	220/380	50	1500	4	F	9

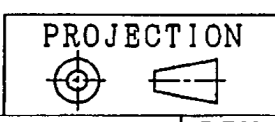
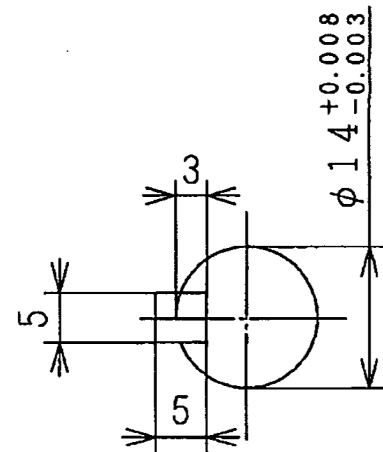
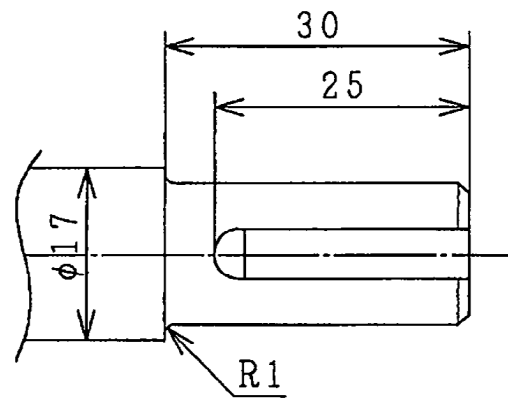
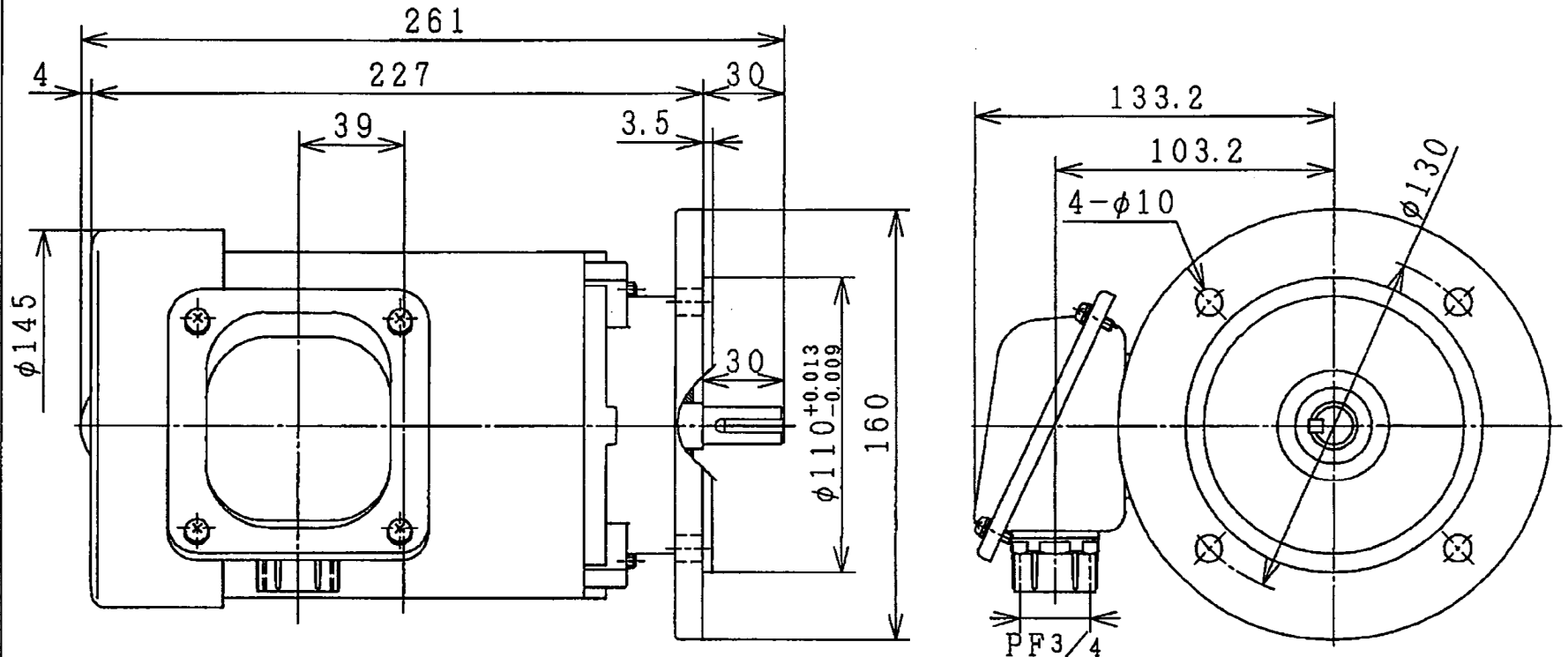

CUSTOMER			QTY.	ORDER No.	WORK No.	REV.
DWN. P. TIANCHAI	08-01-13	S	HITACHI Hitachi Industrial Technology (Thailand) Ltd.		HITT WORKS DWG. No.	SH.
CHKD. W. THAWAT					DIMENSIONS	4HTD02477
APPD. T. SHIMOZONO						
FRAME SIZE VTFOB-FF130 (71M)						