

# THREE-PHASE INDUCTION MOTOR

OUTPUT	TYPE	FORM	RATING	VOLTAGE (V)	FREQ. (Hz)	SYNC. SPEED (min <sup>-1</sup> )	POLES	INS. CLASS	MASS (kg)
10HP	VTFO	K	S1	220/380V	50	1500	4	F	52
7.5HP	VTFO	K	S1	220/380V	50	1000	6	F	57

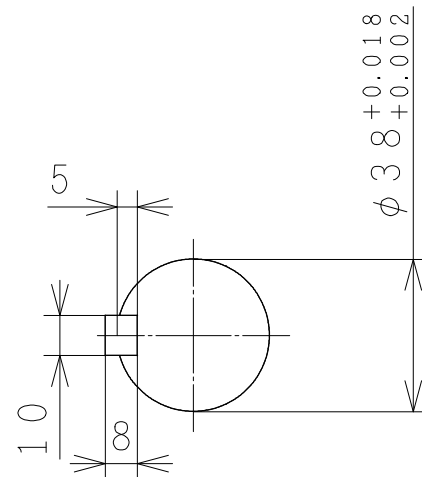

PROTECTION: IP55

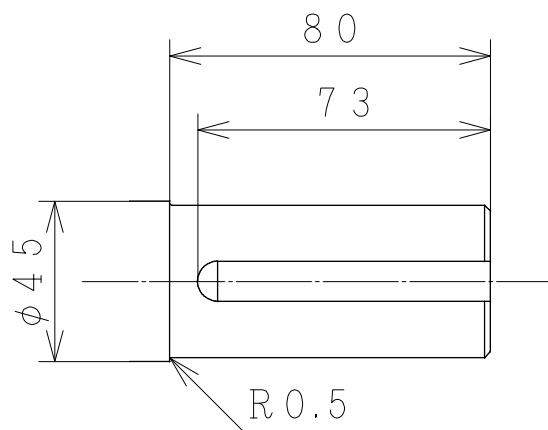
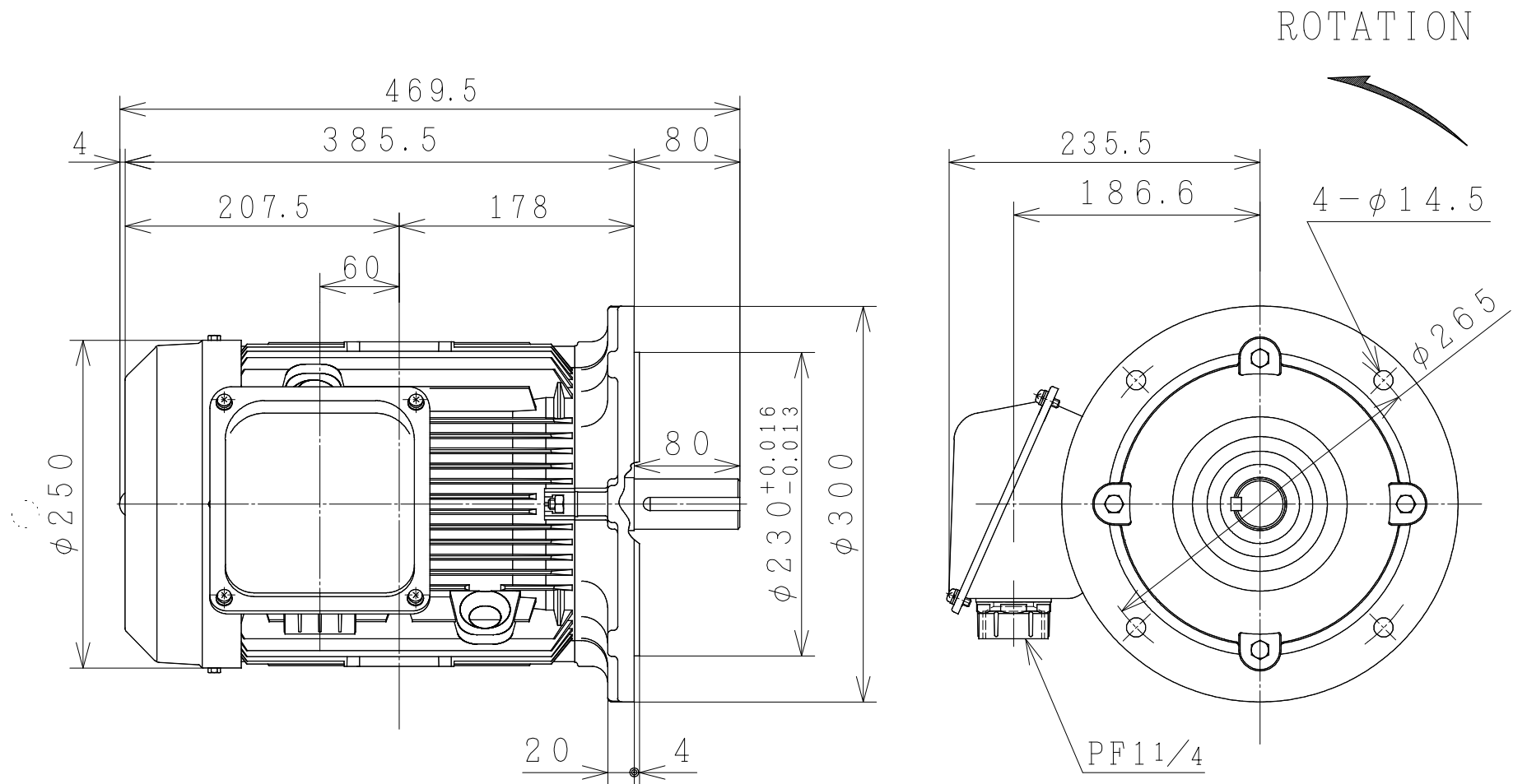
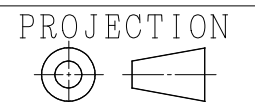

CUSTOMER			QTY.	ORDER NO.	WORK NO.	REV.
DWN	W.Kanchit	22-Jun-2015				SH.
CHKD	W.THAWAT	S	DIMENSIONS		<b>HITACHI</b> Hitachi Industrial Technology (Thailand), Ltd.	4HTD03117
APPD	T.SHIMOZONO		FRAME SIZE	VTFOF-FF265 (132M)		