

三相誘導電動機 THREE-PHASE INDUCTION MOTOR

出力 OUTPUT	形 TYPE	式 FORM	定格 RATING	電圧 VOLTAGE (V)	周波数 FREQ. (Hz)	同期回転速度 SYNC. SPEED (min <sup>-1</sup> )	極数 POLES	耐熱クラス TH. CLASS	質量 MASS (kg)
50HP	TFOA	LKK	S1	380/415	50	1500	4	F	325
60HP	TFOA	LKK	S1	380/415	50	1500	4	F	330
40HP	TFOA	LKK	S1	380/415	50	1000	6	F	315
50HP	TFOA	LKK	S1	380/415	50	1000	6	F	340

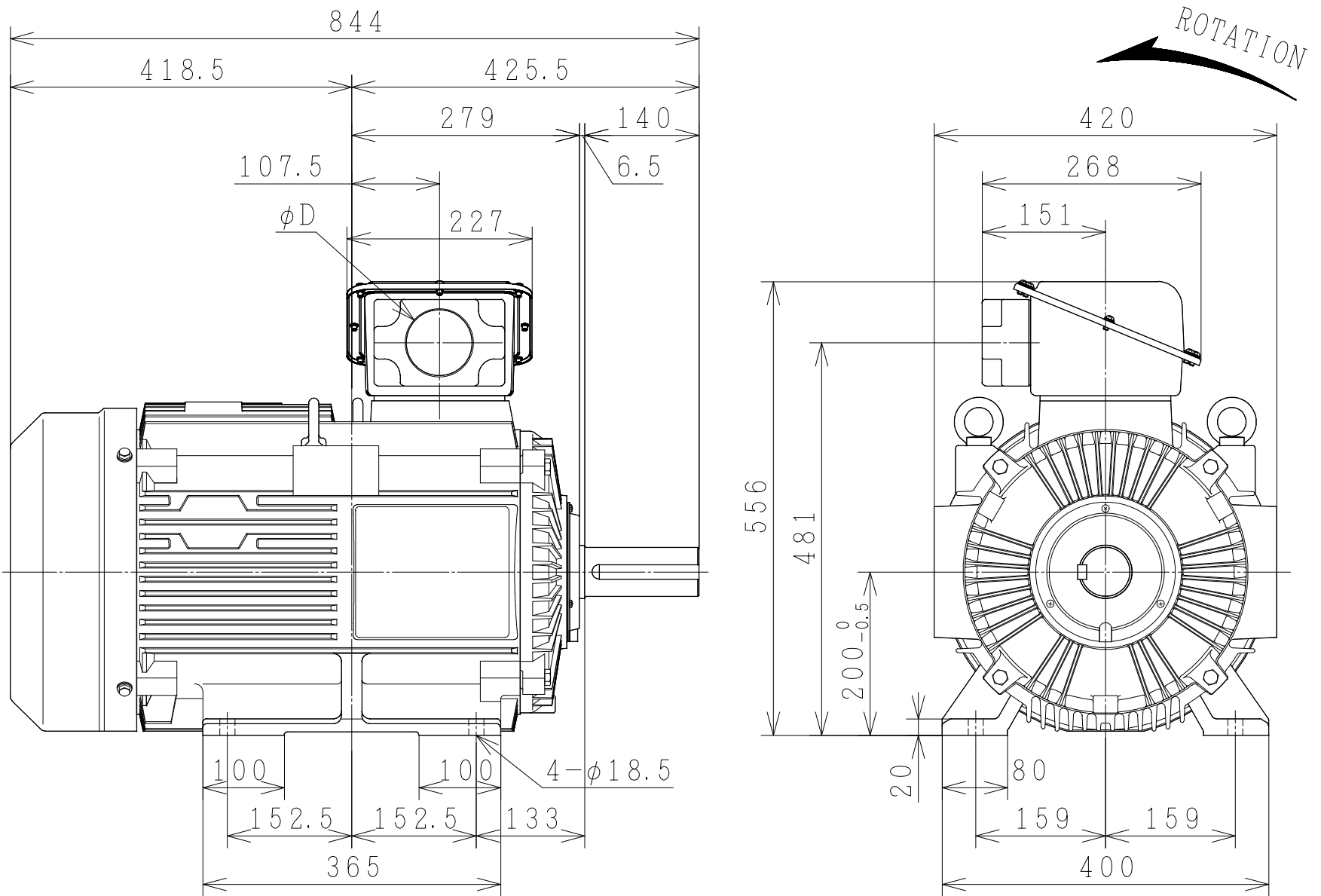

	φD
	PF1 1/4
	PF1 1/2
	PF2
	PF2 1/2
	PF3

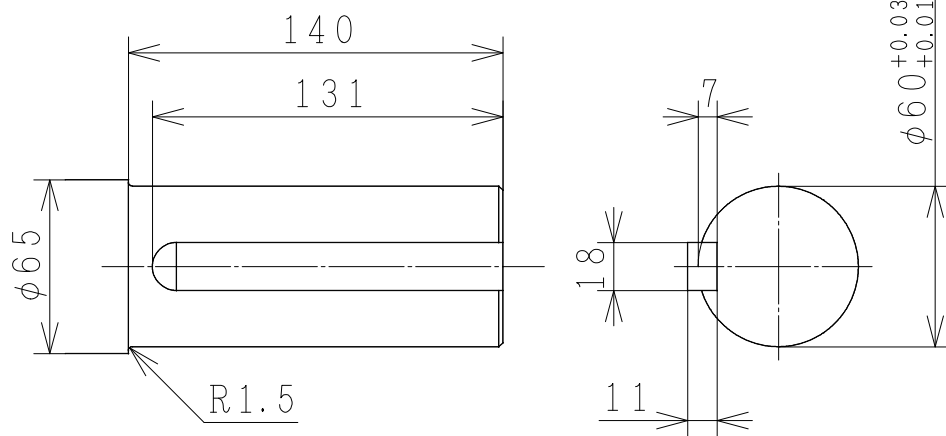

PROTECTION : IP55

保護方式 (PROTECTION)	塗装色 (COLOR)	
軸受 (BRG.)	反負荷側 (O. S.)	負荷側 (D. S.)

用途 USE \_\_\_\_\_ 付属品 ACCESSORY \_\_\_\_\_

備考 NOTICE

御注文主 CUSTOMER	数量 QTY.	受注番号 ORDER NO.	作業番号 WORK NO.	REV.
---------------	---------	----------------	---------------	------

DWN. C. Saknarin	05-Oct-2015	寸法図 DIMENSIONS	HITACHI Hitachi Industrial Technology (Thailand), Ltd.	NARASHINO DWG. NO.	SH.
CHKD. P. Damrongsak				3244HTD03274	
APPD. T. Shimozono					

枠番 FRAME SIZE TFOAL-200L