

THREE-PHASE INDUCTION MOTOR

OUTPUT	TYPE	FORM	RATING	VOLTAGE (V)	FREQ. (Hz)	SYNC. SPEED (min ⁻¹)	POLES	TH. CLASS	MASS (kg)
25HP	TFO	KK	S1	380/415	50	3000	2	F	85
20HP	TFO	KK	S1	380/415	50	1500	4	F	85
15HP	TFO	KK	S1	380/415	50	1000	6	F	90

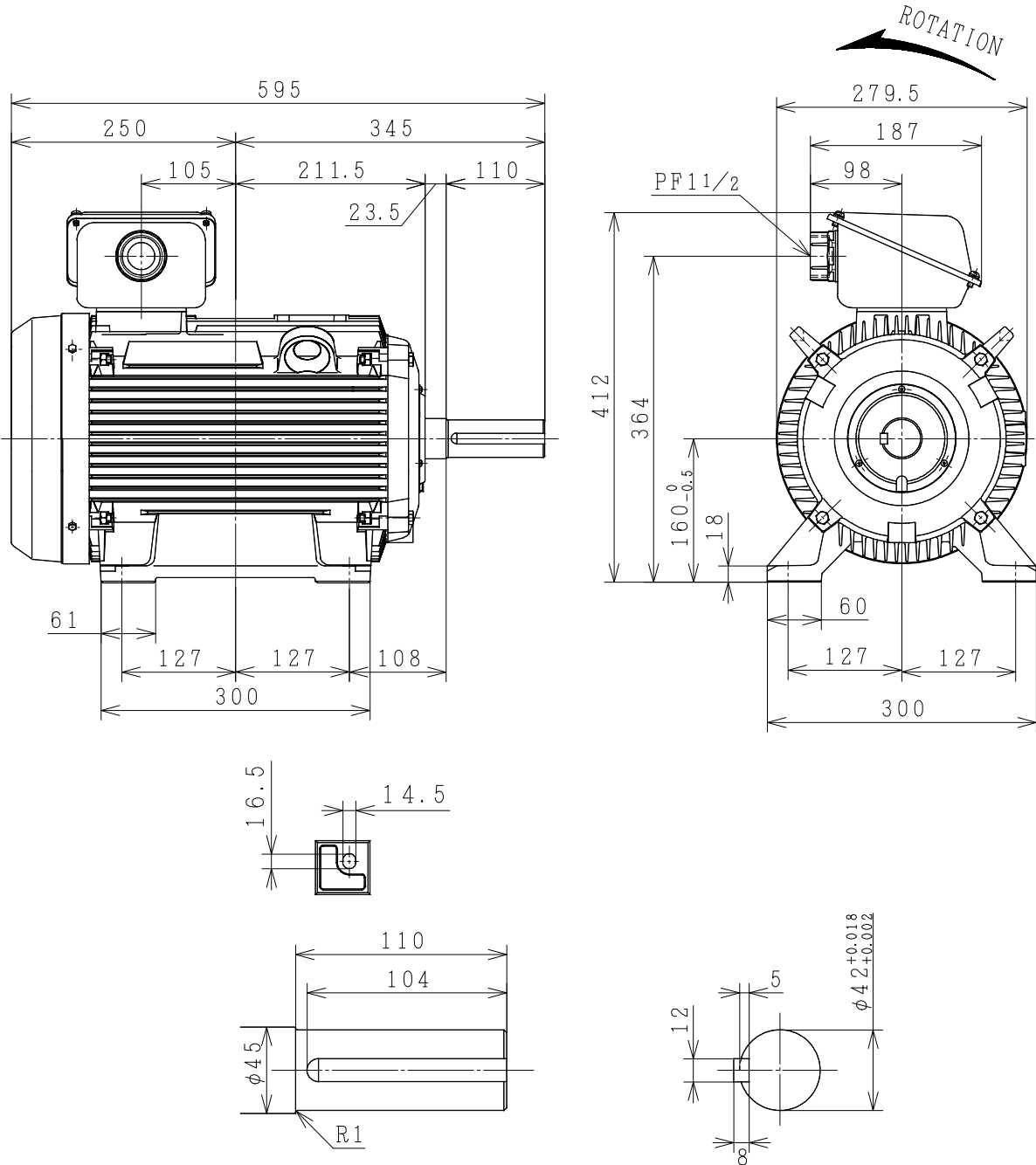

ROTATION
↙

PROTECTION : IP55



CUSTOMER	QTY.	ORDER No.	WORK No.	REV.
<h1 style="font-size: 2em;">DIMENSIONS</h1>	HITACHI Hitachi Industrial Technology (Thailand), Ltd.		HITT WORKS DWG. No. 4HTD03372	SH.
FRAME SIZE TFOD-160L (TMHD)				