

三相誘導電動機
THREE-PHASE INDUCTION MOTOR

| 出力 OUTPUT | 形 TYPE | 式 FORM | 定格 RATING | 電圧 VOLTAGE (V) | 周波数 FREQ. (Hz) | 同期回転速度 SYNC. SPEED (min ⁻¹) | 極数 POLES | 耐熱クラス TH. CLASS | 質量 MASS (kg) |
|--------------|-----------|-----------|--------------|-------------------|-------------------|--|-------------|--------------------|-----------------|
| 2HP | TFO | LK | S1 | 220/380 | 50 | 3000 | 2 | F | 17 |
| 3HP | TFO | LK | S1 | 220/380 | 50 | 3000 | 2 | F | 20.5 |
| 2HP | TFO | LK | S1 | 220/380 | 50 | 1500 | 4 | F | 19 |
| 1HP | TFO | LK | S1 | 220/380 | 50 | 1000 | 6 | F | 20.5 |

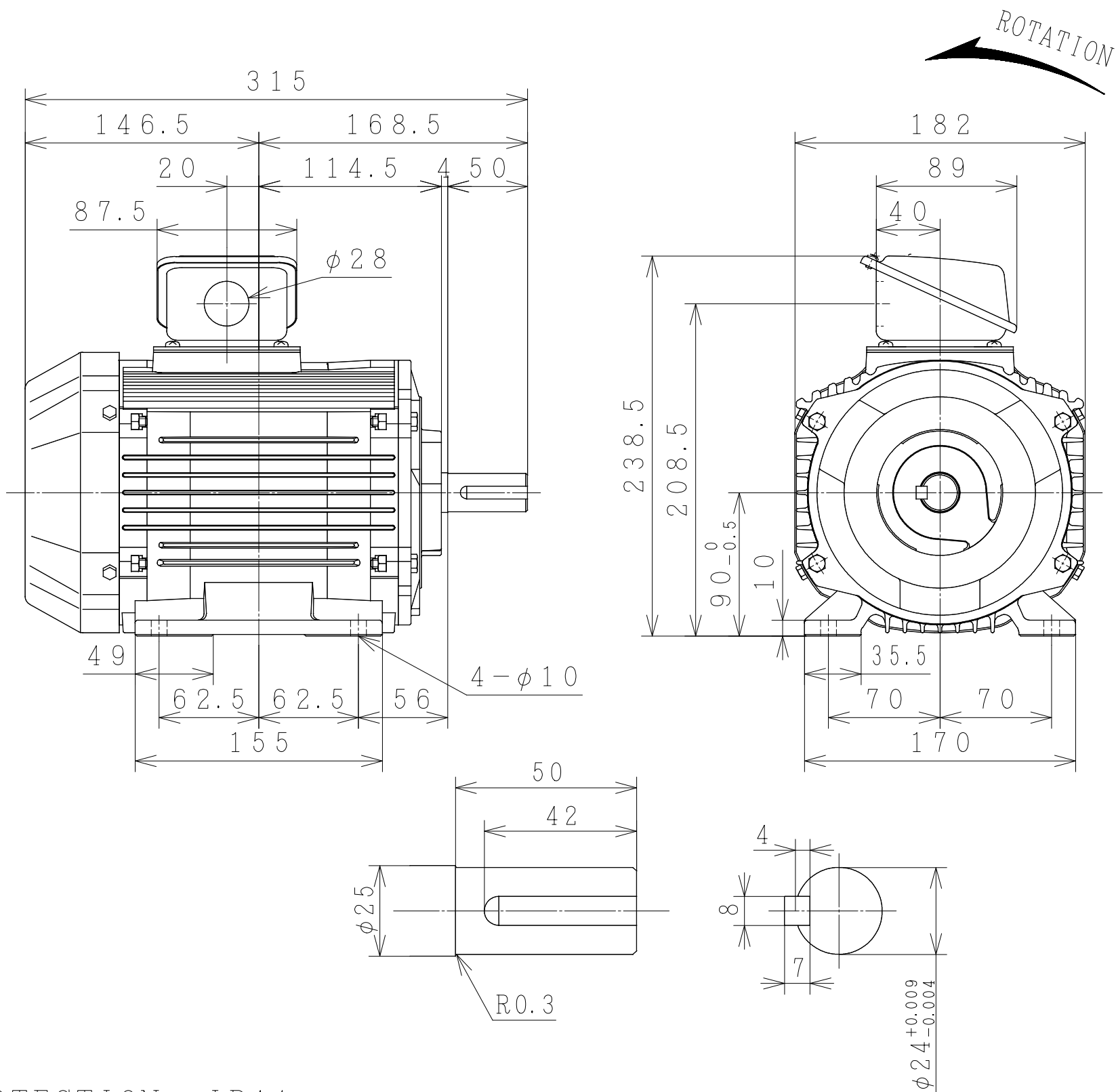

PROTECTION : IP44

| | | | |
|-------------|----------------------|---------------------------|----------------------|
| ベース BASE | 付 WITH 不付 WITHOUT | キソボルト FOUNDATION BOLTS | 付 WITH 不付 WITHOUT |
|-------------|----------------------|---------------------------|----------------------|

用途 USE _____ 付属品 ACCESSORY _____

備考 NOTICE

| | | | | |
|---------------|---------|----------------|---------------|------|
| 御注文主 CUSTOMER | 数量 QTY. | 受注番号 ORDER NO. | 作業番号 WORK NO. | REV. |
|---------------|---------|----------------|---------------|------|

| | | | | | |
|---------------------|-------------|------------------|---|--------------------|-----|
| DWN. M. NARUBESS | 22-MAR-2016 | 寸法 DIMENSIONS | HITACHI Hitachi Industrial Technology (Thailand), Ltd. | NARASHINO DWG. NO. | SH. |
| CHKD. P. DAMRONGSAK | S | | | 3244HTD03399 | |
| APPD. T. SHIMOZONO | | | | | |

枠番 FRAME SIZE TFO L-90 L (TMHD)