

R-NZG EARTH-LEAKAGE RELAY (STANDARD TYPE)

Rated Voltage (AC, V)	Frequency (Hz)	Rated sensitivity Current (mA)	Operating time (S)	Alarm Contact	Base Amb. Temp. (°C)	Weight (kg)
100-440	50-60	50 · 100 · 200 500 · 1000 (30)	0.1 or less	1c + 1a	40	0.25

Rated sensitivity current selector

(Use flathead screw driver)

	Latching system	Reset operation
Indication Lamp	Electrical Latch	Push the reset button or turn off a power source
Alarm Contact	Electrical Latch	Push the reset button or turn off a power source

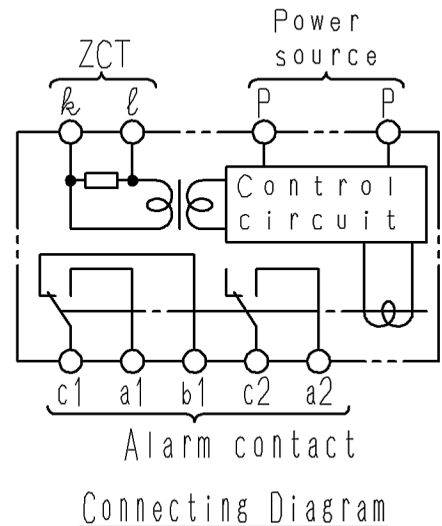
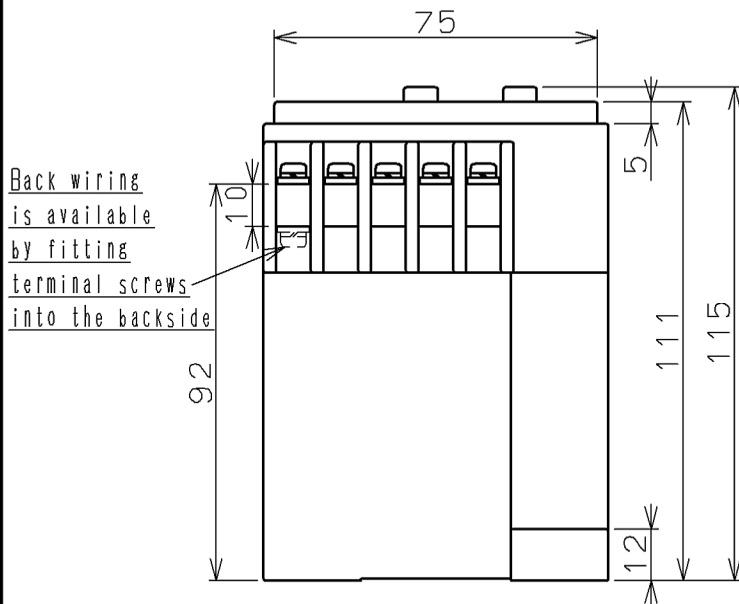
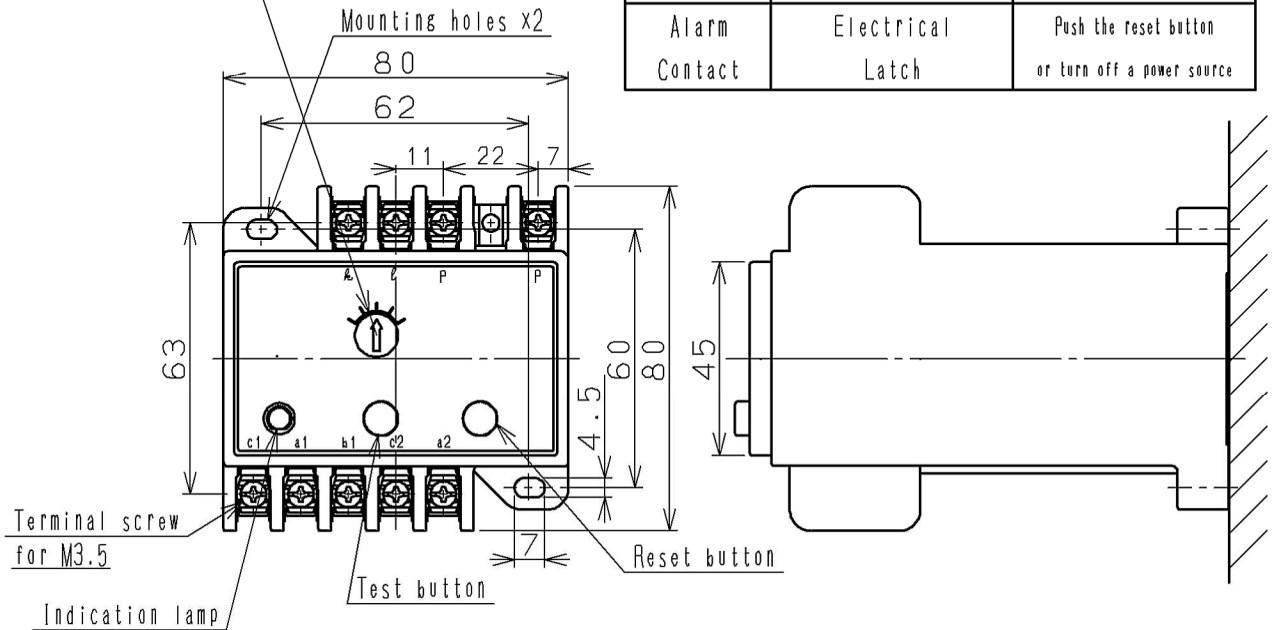

CUSTOMER			DWN.	<i>H. Miyajima</i>	Nov-30-2012	REGD 2012-11 30	TITLE	R-NZG DIMENSION	REV.	00
			CHKD.	<i>D. Nakamura</i>	Nov-30-2012		APPD.		<i>H. Aikawa</i>	
QUANTITY	ORDER NO.	WORK NO.	Hitachi Industrial Equipment Systems Co., Ltd.			NAKAJO WORKS DWG. NO. 325 43069277		SH.	1 1	