

F-1200C FUSE FREE BREAKER

Type	Pole	Net weight (kg)	Rated Voltage (V)	Rated Current (A)	Base Amb. Temp.
F-1200C	3	26	AC600	600 700 800 1000 1200 (Adjustable)	40°C

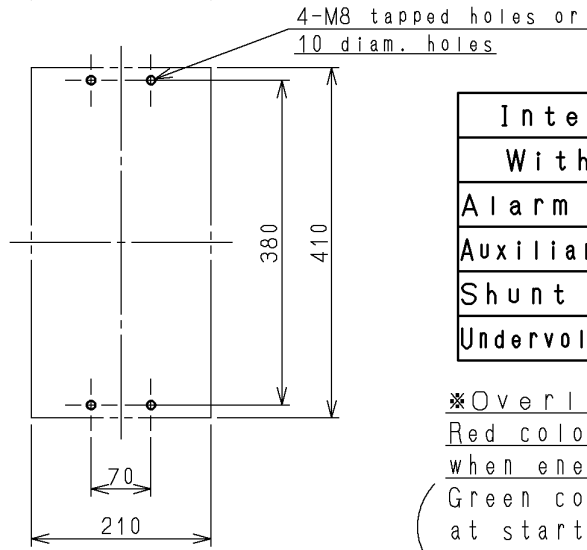
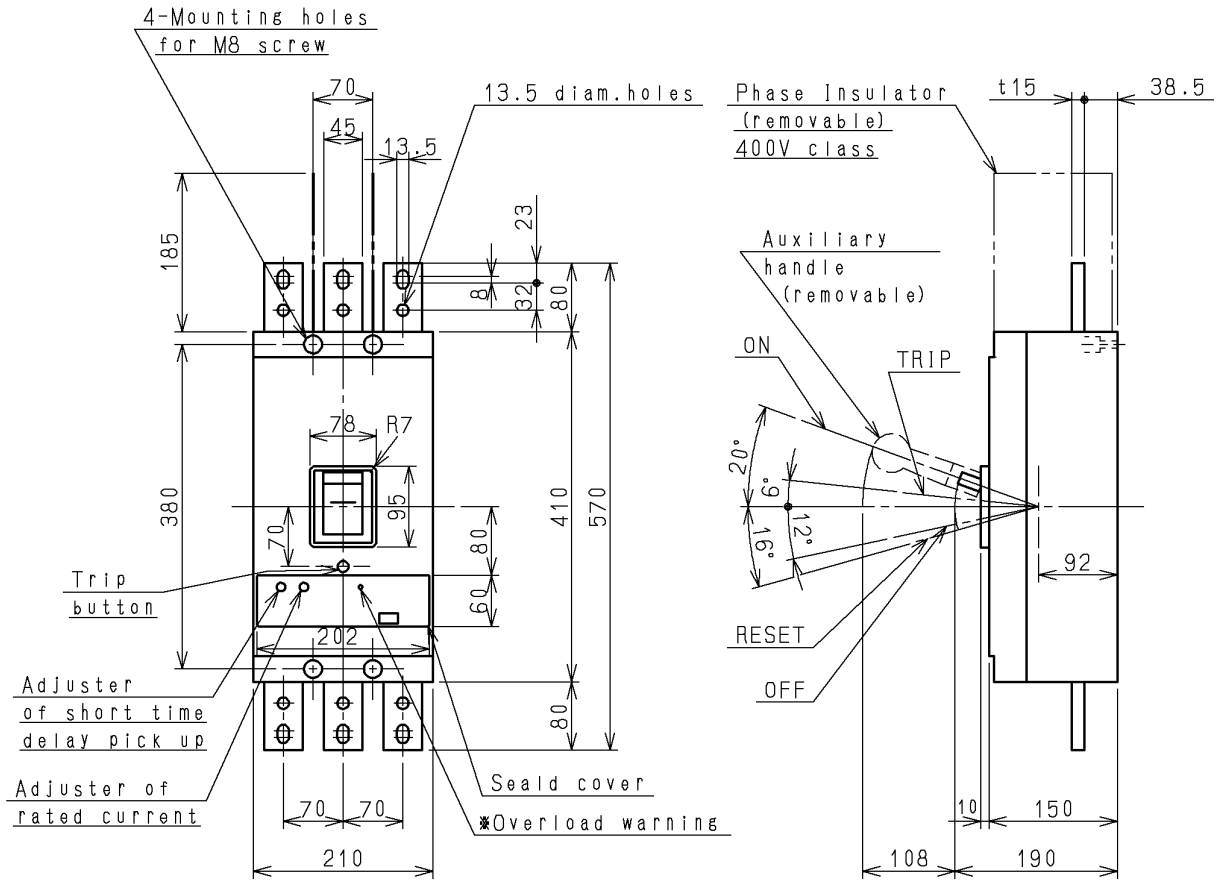

Interior Accessories With Front Terminal	
Alarm Switch (AL)	C
Auxiliary Switch (AUX)	C
Shunt Trip (SHT)	V
Undervoltage Trip (UVT)	V

*Overload warning
 Red color LED will be blinking when energizing over current.
 (Green color will be displayed at start current value 90% of overload.)

CUSTOMER			DWN. <i>R. Hazama</i> Nov-18-2002		TITLE	REV.
QUANTITY			CHKD. <i>S. Sugai</i> Nov-18-2002		Dimensions	00
ORDER NO.			APPD. <i>T. Kashima</i> Nov-18-2002			SH.
WORK NO.			Hitachi Industrial Equipment Systems Co., Ltd.		NAKAJO WORKS DWG. NO. 325 43059446	