

HITACHI MOLDED CASE CIRCUIT BREAKER

Type	Poles	Rated Insulation Voltage (Ui)	IEC 60947-2 Icu/Ics [kA]		Rated Current	Base Ambient Temperature	Weight
			230V	400V			
FX1200	3	690 V	125/125	85/85	600/700/800/1000/1200 Adjustable A	40 °C	26 kg

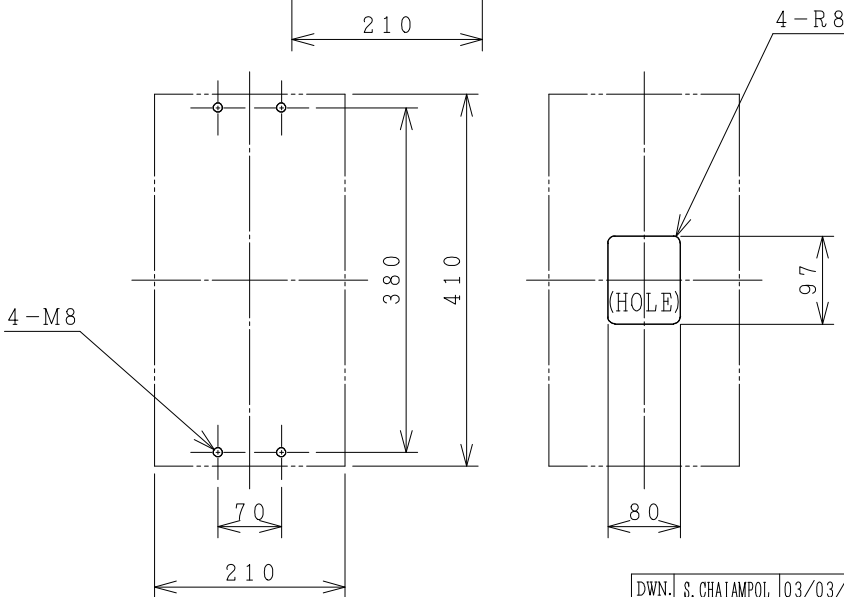
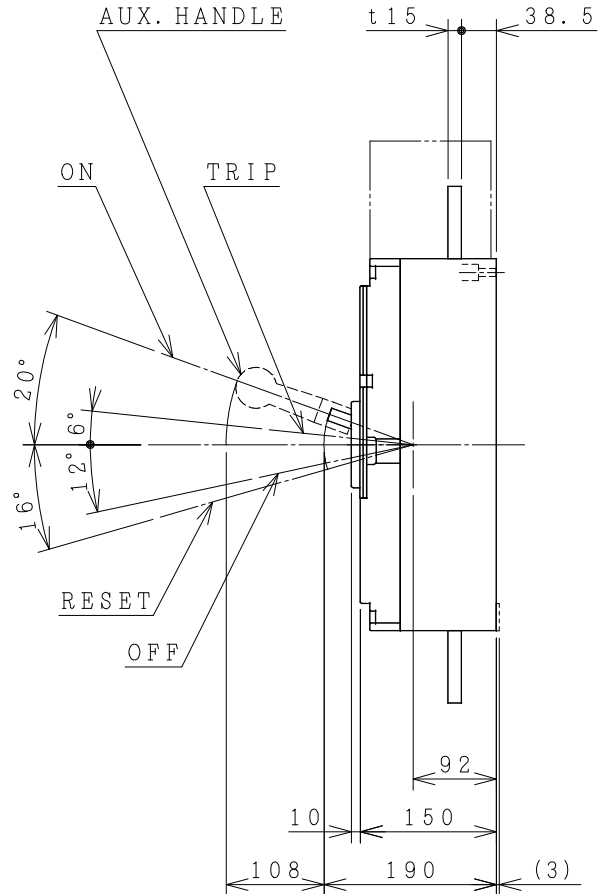
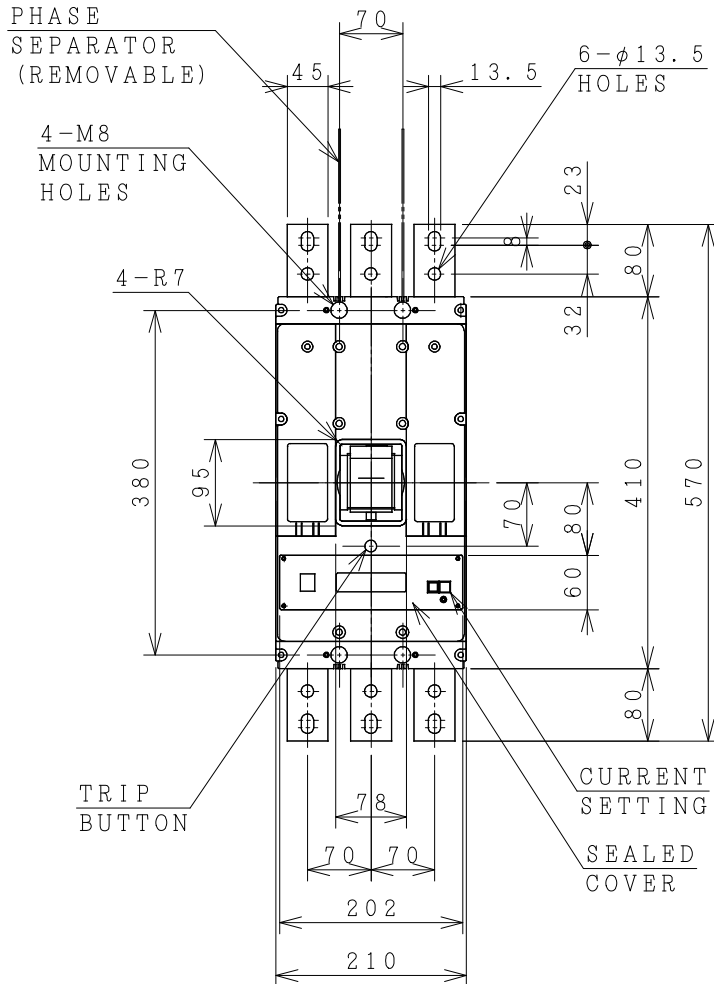

ACCESSORIES		
Part	Size	Q'ty
Phase separator	-	4
Terminal screw/bolt	M12x50	12
Mounting screw	M8x40	4
Assistant handle	-	1
Interior accessories AL, AUX, SHT, UVT		

FRONT PLATE CUTOUT.
 -THESE DIMENSIONS THE HEIGHT OF FRONT PLATE FROM BASE OF CASE TO COVER IS 150mm.
 -CLEARANCE 1mm ON EACH SIDE OF HANDLE.

DRILLING PLAN.

DWN. S. CHAIAMPOL	03/03/17	PROJECTION	TITLE
CHKD. J. Imdee		SCALE	DIMENSION OF FX1200
APPD. C. Krathisak		NTS.	
HITT WORKS DWG. No.			REV.
HITACHI Hitachi Industrial Technology (Thailand), Ltd.			00
			01
			01

(Reference 43052042R02).
 ※REMARK
 -DIMENSION UNIT = Millimeter (mm).

4HTN000971