

# HITACHI MOLDED CASE CIRCUIT BREAKER

Type	Poles	Rated Insulation Voltage (Ui)	IEC 60947-2 Icu/Ics [kA]		Rated Current	Base Ambient Temperature	Weight
			230V	400V			
F-1600EB	4	690 V	125/94	100/75	800/900/1000 1200/1400/1600 Adjustable A	40 °C	△ 35 kg

67 (DIMENSION OF CONNECTION)

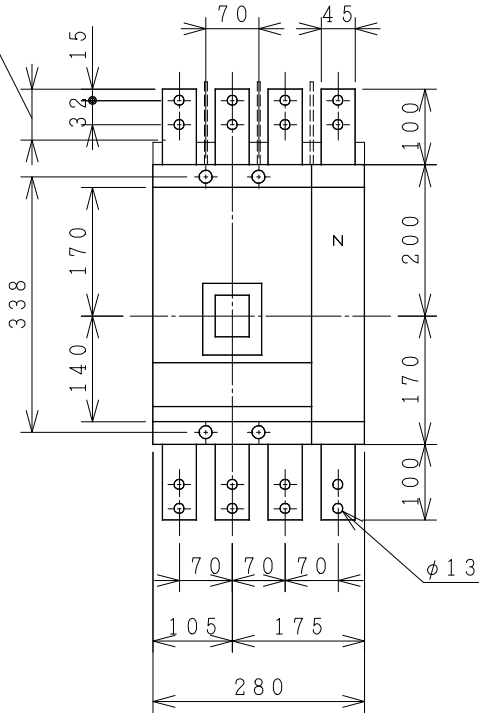

※DIMENSION COMMON 2P & 3P (2P NO WIRING S PHASE)

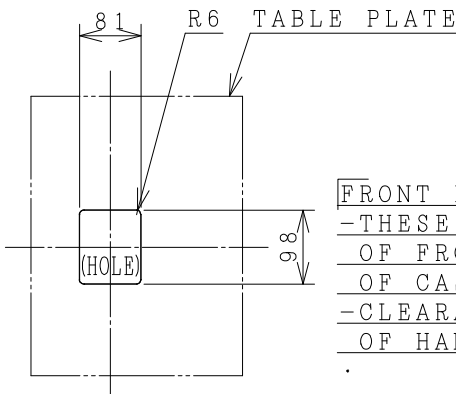

FRONT PLATE CUTOUT.  
 -THESE DIMENSIONS THE HEIGHT OF FRONT PLATE FROM BASE OF CASE TO COVER IS 68mm.  
 -CLEARANCE 1mm ON EACH SIDE OF HANDLE.

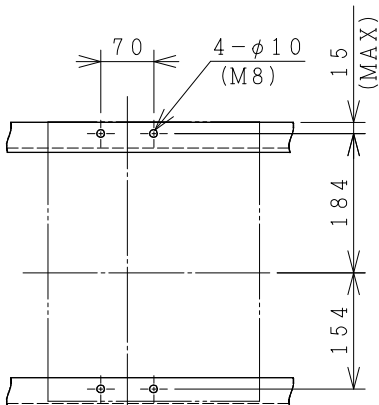

DRILLING PLAN.

ACCESSORIES		
Part	Size	Q'ty
Phase separator	-	3
Terminal screw/bolt	M12	16
Mounting screw	M8x50	4
Assistant handle	-	1

Interior accessories AL, AUX, SHT, UVT, TB

(Reference 33038405R01).

※REMARK

-DIMENSION UNIT = Millimeter (mm).

DWN. S. CHAIAMPOL	06/03/17	PROJECTION	TITLE
CHKD. J. Imdee	S	SCALE NTS.	DIMENSION OF F-1600EB
APPD. T. Sotiguch			
HITT WORKS DWG. No.			REV.
<b>HITACHI</b> Hitachi Industrial Technology (Thailand), Ltd.			01
			SH.
			01
			01