

HITACHI MOLDED CASE CIRCUIT BREAKER

Type	Poles	Rated Insulation Voltage (Ui)	IEC 60947-2 Icu/Ics [kA]		Rated Current	Base Ambient Temperature	Weight
			230V	400V			
F-2000E	4	690 V	125/94	100/75	1000/1200/1400 1600/1800/2000 Adjustable A	40 °C	67 kg

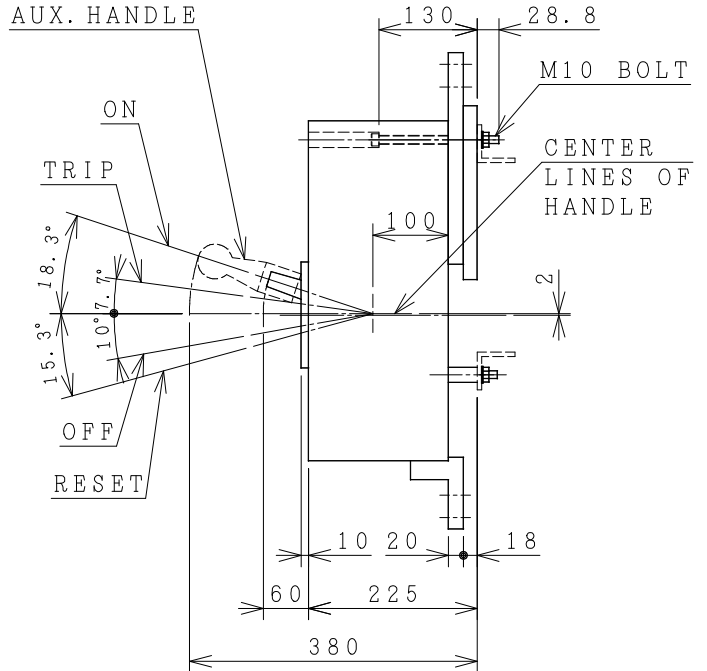
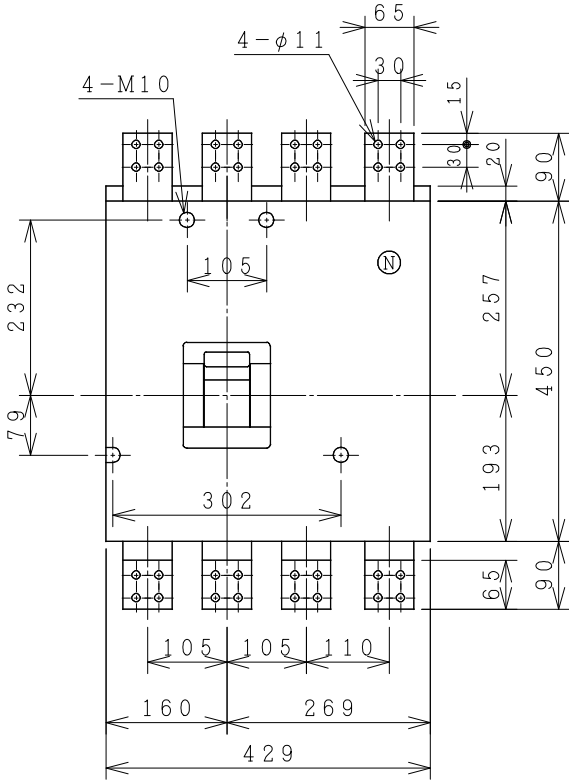

※DIMENSION COMMON 2P & 3P
(2P NO WIRING S PHASE)

FRONT PLATE CUTOUT.

- THESE DIMENSIONS THE HEIGHT OF FRONT PLATE FROM BASE OF CASE TO COVER IS 68mm.
- CLEARANCE 1mm ON EACH SIDE OF HANDLE.

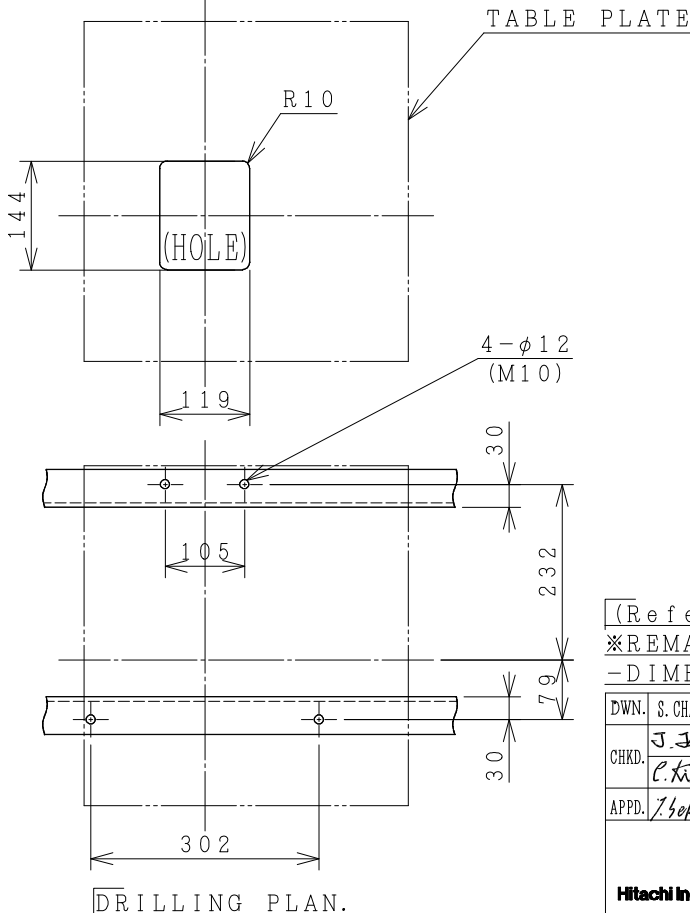

DRILLING PLAN.

ACCESSORIES		
Part	Size	Q'ty
Phase separator	-	-
Terminal screw/bolt	M10	32
Mounting screw	M10x160	4
Assistant handle	-	1

Interior accessories | AL, AUX, SHT, UVT, TB

(Reference 33033570R02).

※REMARK

-DIMENSION UNIT = Millimeter (mm).

DWN. S. CHAIAMPOL	08/03/17	PROJECTION	TITLE
CHKD. J. Imdee		SCALE	DIMENSION OF F-2000E
APPD. T. Kiatthasak		NTS.	
HITT WORKS DWG. No.			REV.
HITACHI Hitachi Industrial Technology (Thailand), Ltd.			00
			01
			01
			01

4HTN000977