

HITACHI ELECTROMAGNETIC SWITCH

Type	Rated insulation voltage (Ui)	Max. rated capacity of motor			Rated thermal current (AC1 = Ith)	Applicable standard	Aux. Contact	Weight
		240V	15kW	50A				
SHS50-TB	AC 690	240V	15kW	50A	60 A	IEC 60947-4-1	2a2b	2.9 kg
	V	440V	22kW	50A				

φ 22-28 KNOCKOUT
(ONE ON EACH SIDE)

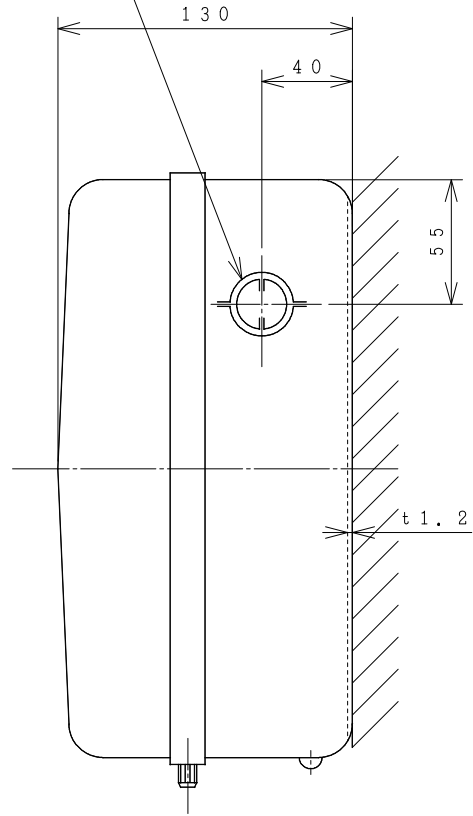
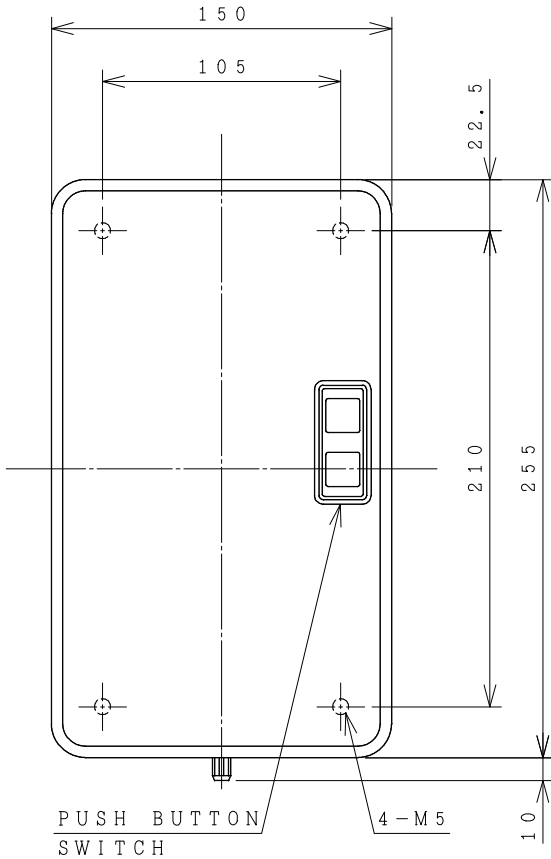

OUTLINE DIMENSIONS.

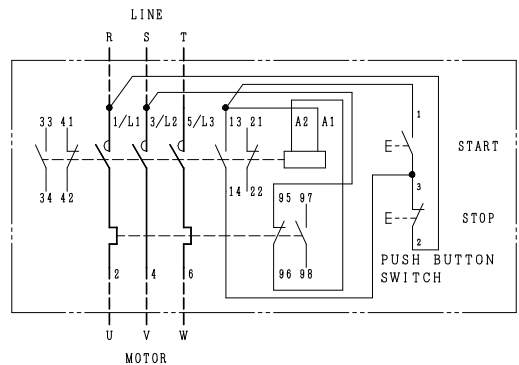
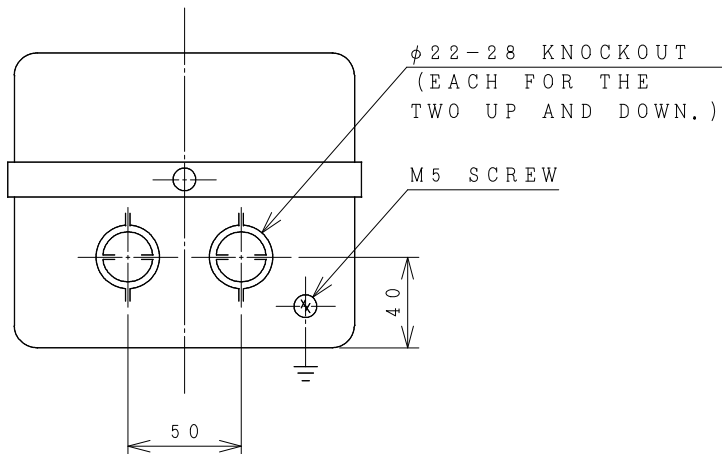

CONTACTS ARRANGEMENT.

(Reference 43068444R01).

※REMARK

- DIMENSION UNIT = Millimeter (mm).
- (a) = AUX. CONTACT NORMALLY OPENED.
- (b) = AUX. CONTACT NORMALLY CLOSED.

		TERMINAL SCREW	WIDTH OF TERMINAL
MAIN CIRCUIT	CONTACTOR	M5	13.9
	OVERLOAD RELAY	M5	13
OPERATION CIRCUIT	CONTACTOR	M3.5	7.8
	OVERLOAD RELAY	M3.5	7.8

DWN. O. SITTICHAJ 22/08/16	PROJECTION	TITLE
CHKD. <i>C. Kiatissak</i>	SCALE NTS.	DIMENSION OF SHS50-TB
APPD. <i>T. Kiatissak</i>		
HITT WORKS DWG. No.		REV.
HITACHI Hitachi Industrial Technology (Thailand), Ltd.		00
		SH.
		01
		01

4HTN000843