

# HITACHI ELECTROMAGNETIC SWITCH

Type	Rated insulation voltage (Ui)	Max. rated capacity of motor			Rated thermal current (AC1 = Ith)	Applicable standard	Aux. Contact	Weight
		240V	3kW	12A				
H12-RT	AC 660 V	240V	3kW	12A	20 A	IEC 60947-4-1	2a1b x2 or 1a2b x2	0.88 kg
H12-RTK		440V	4kW	9A				

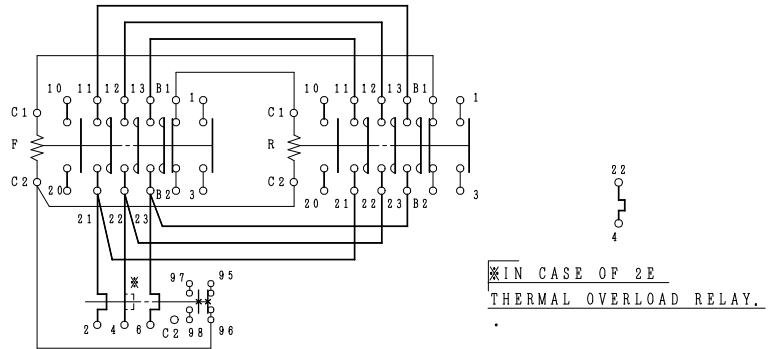
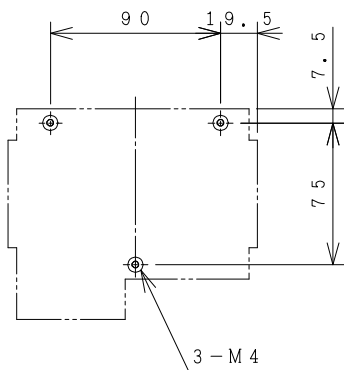
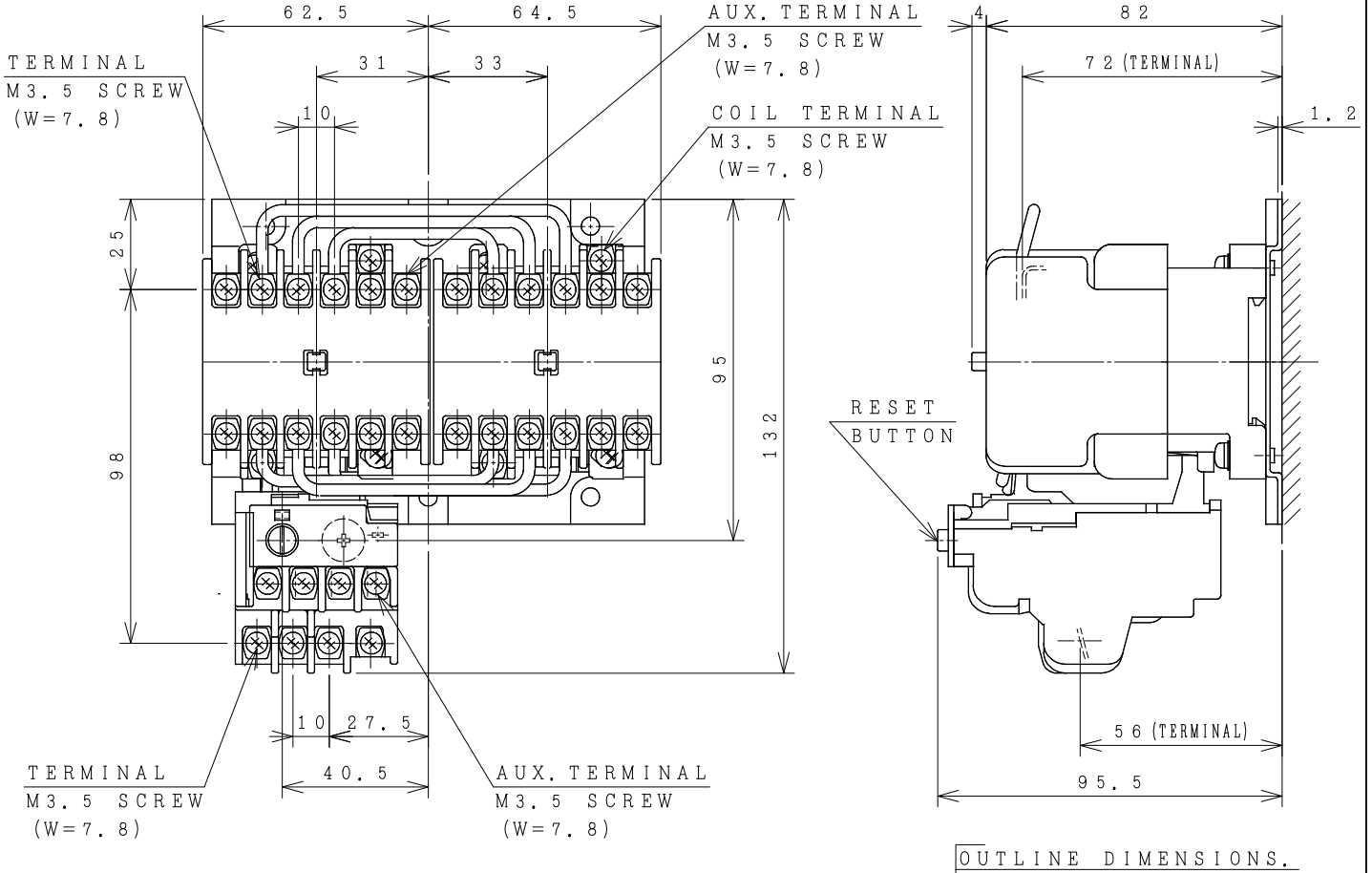

CONTACTS ARRANGEMENT.

(Reference 43046449R01).

REMARK

- DIMENSION UNIT = Millimeter (mm).
- (a) = AUX. CONTACT NORMALLY OPENED.
- (b) = AUX. CONTACT NORMALLY CLOSED.

DWN. C. JERRANAN	30/08/16	PROJECTION	TITLE
CHKD. <i>Jan-a</i>		SCALE	DIMENSION OF H12-RT, RTK
APPD. <i>C. Kiattisak</i>		NTS.	
HITACHI Hitachi Industrial Technology (Thailand), Ltd.			HITT WORKS DWG. No. 4HTN000853
			REV. 00 SH. 01 01

(W=) : WIDTH OF TERMINAL.