

HITACHI ELECTROMAGNETIC CONTACTOR

Type	Rated insulation voltage (Ui)	Max. rated capacity of motor			Rated thermal current (AC1 = Ith)	Applicable standard	Aux. Contact	Weight
H65C-G	AC 660 V	240V	18.5kW	65A	80 A	IEC 60947-4-1	2a2b	2.1 kg
		440V	30kW	65A				

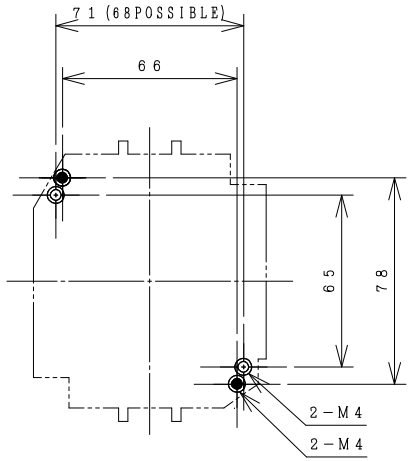
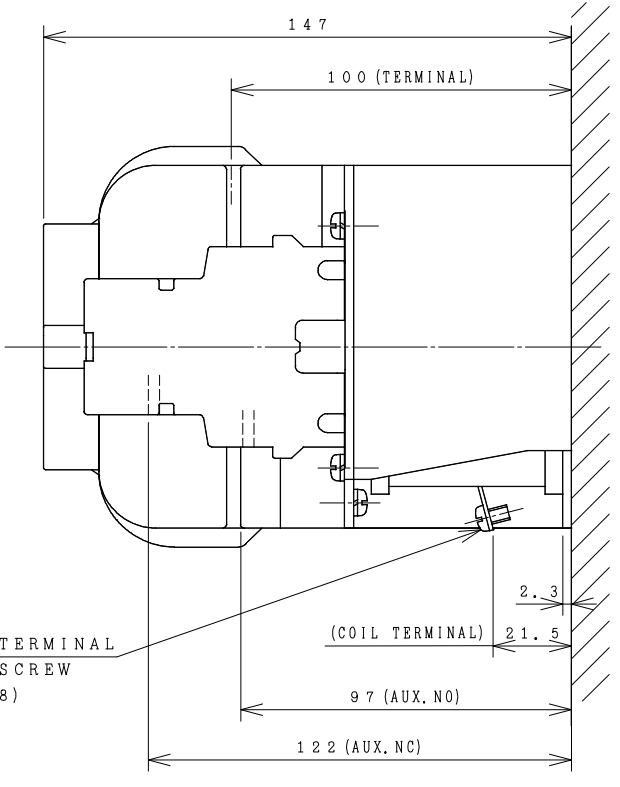
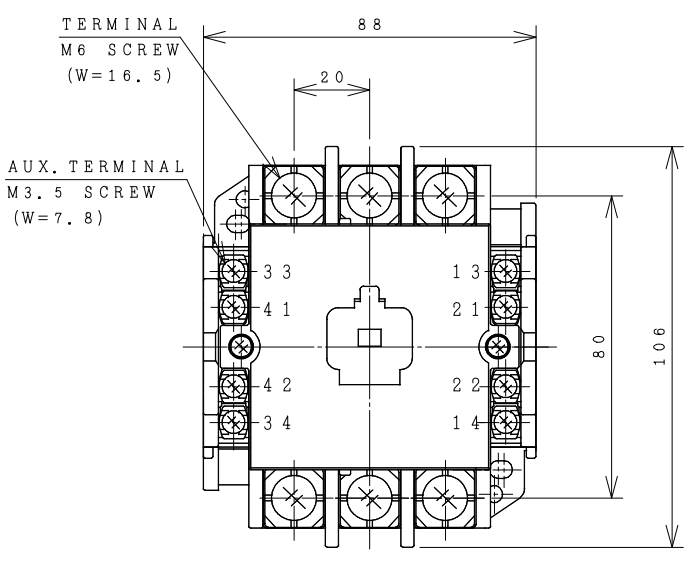

● ALSO POSSIBLE.

OUTLINE DIMENSIONS.

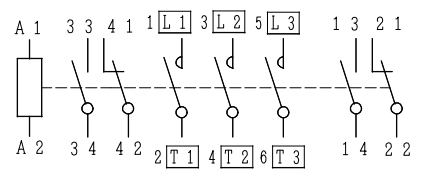

CONTACTS ARRANGEMENT.

MOUNTING HOLES.

(Reference 43056033R01).

REMARK

- DIMENSION UNIT = Millimeter (mm).
- (a) = AUX. CONTACT NORMALLY OPENED.
- (b) = AUX. CONTACT NORMALLY CLOSED.

DWN. S. CHAIAMPOL	09/08/16	PROJECTION	TITLE
CHKD. <i>Jan-a</i>	S	SCALE NTS.	DIMENSION OF H65C-G
APPD. <i>C.Kiattisak</i>			
HITACHI Hitachi Industrial Technology (Thailand), Ltd.			4HTN000858
			REV.
			00
			01
			01

(W=) : WIDTH OF TERMINAL.