

HITACHI ELECTROMAGNETIC CONTACTOR

Type	Rated insulation voltage (Ui)	Max. rated capacity of motor			Rated thermal current (AC1 = Ith)	Applicable standard	Aux. Contact	Weight
H80C-R	AC 660 V	240V	22kW	80A	120 A	IEC 60947-4-1	(2a2b) x 2	5.0 kg
		440V	37kW	80A				

*WITH AUX. CONTACT (3a3b) x 2 = 243 mm.

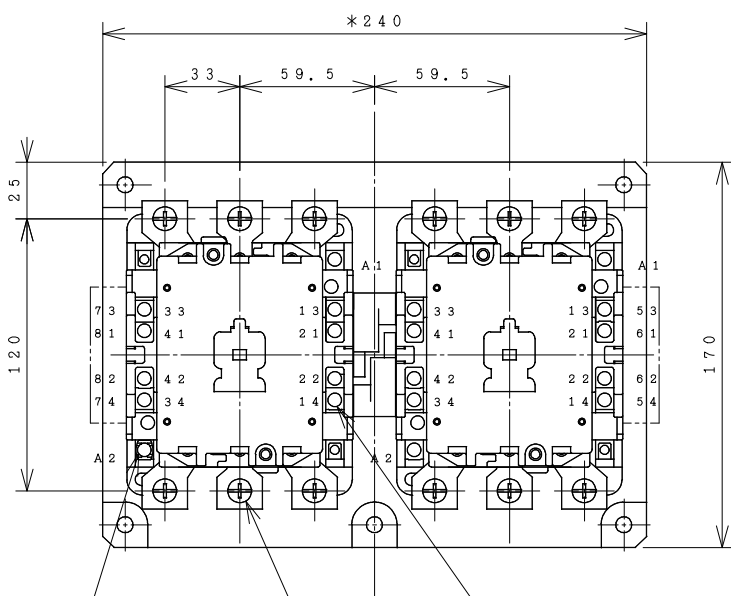

COIL TERMINAL
M3.5 SCREW
(W=7.8)

TERMINAL
M6 SCREW
(W=22)

AUX. TERMINAL
M3.5 SCREW
(W=7.8)

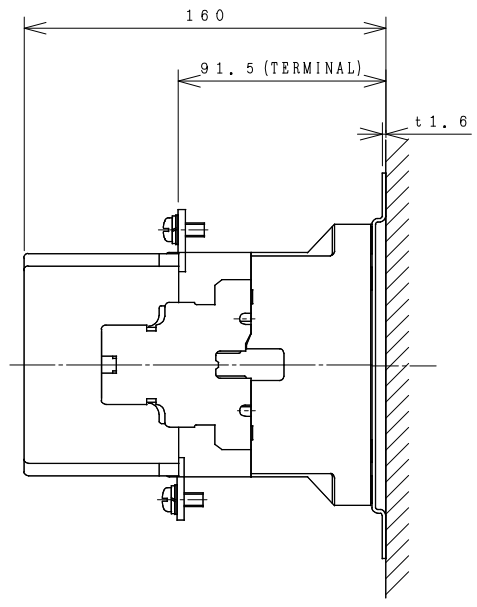

OUTLINE DIMENSIONS.

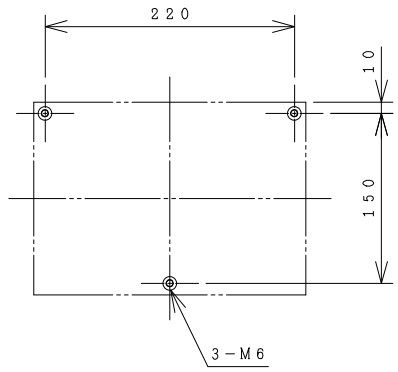

MOUNTING HOLES.

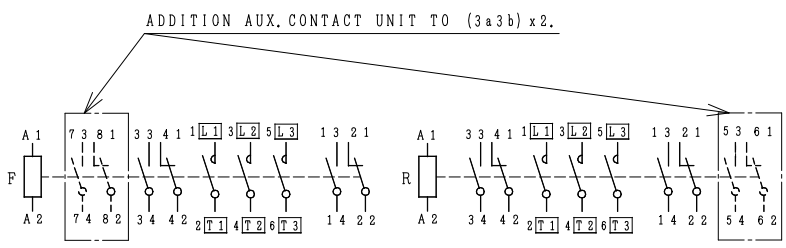

CONTACTS ARRANGEMENT.

(Reference 43056000R01).

- *REMARK
- DIMENSION UNIT = Millimeter (mm.).
 - (a) = AUX. CONTACT NORMALLY OPENED.
 - (b) = AUX. CONTACT NORMALLY CLOSED.

DWN. S. CHAIAMPOL	09/08/16	PROJECTION	TITLE
CHKD. <i>Jan-a</i>	S	SCALE NTS.	DIMENSION OF H80C-R
APPD. <i>C.Kiattisak</i>			
HITACHI Hitachi Industrial Technology (Thailand), Ltd.			4HTN000865
			REV.
			00
			01
			01

(W=) : WIDTH OF TERMINAL.