

HITACHI ELECTROMAGNETIC SWITCH

Type	Rated insulation voltage (Ui)	Max. rated capacity of motor			Rated thermal current (AC1 = I _{th})	Applicable standard	Aux. Contact	Weight
SH80C-RT	AC 660 V	240V	22kW	80A	80 A	IEC 60947-4-1	(2a2b) x 2	10.5 kg
SH80C-RTK		440V	37kW	80A				

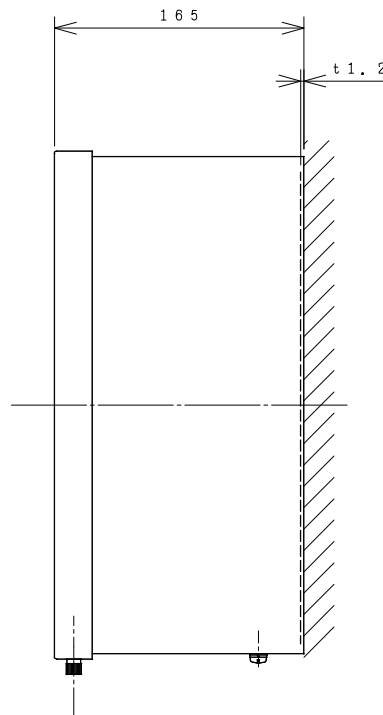

OUTLINE DIMENSIONS.

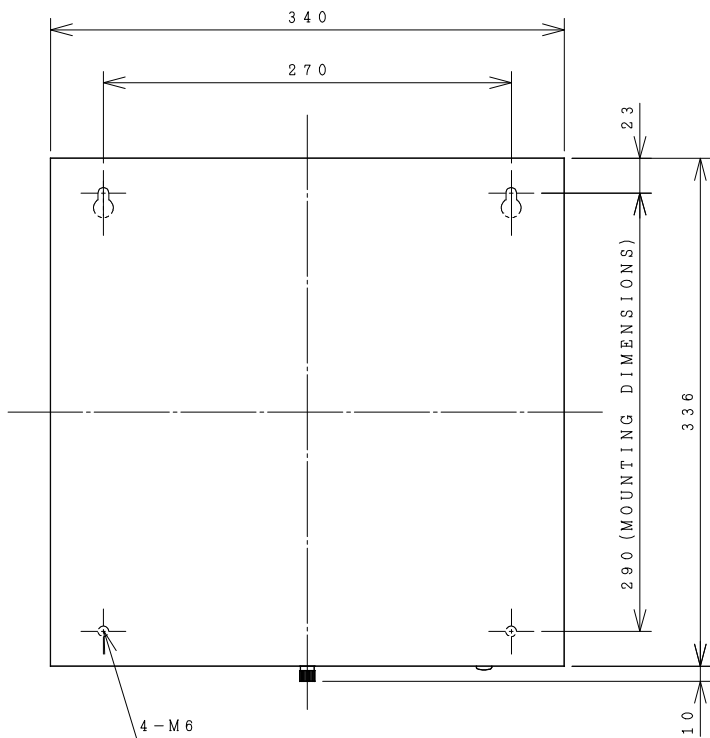
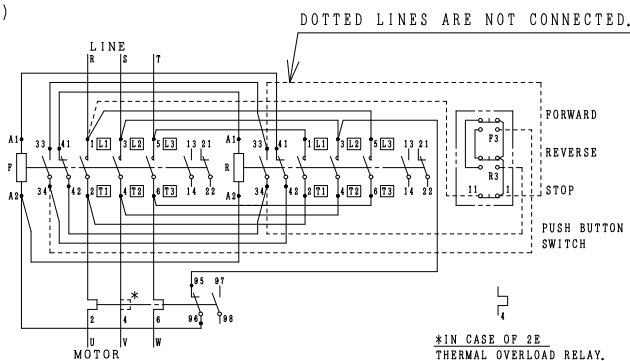
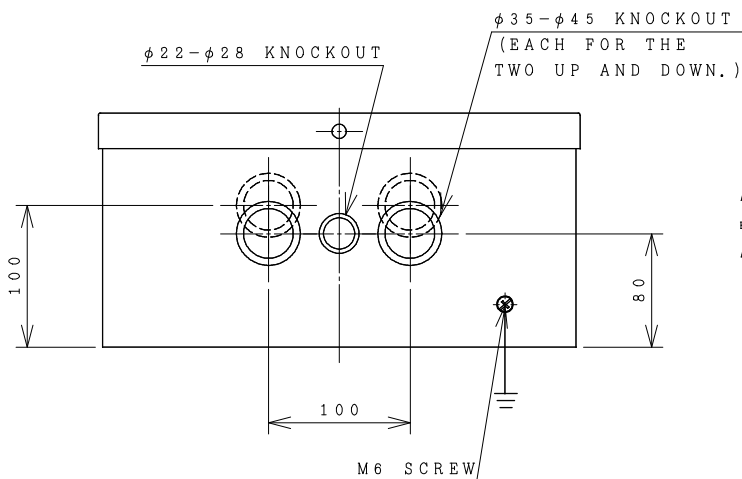

CONTACTS ARRANGEMENT.

		TERMINAL SCREW	WIDTH OF TERMINAL
MAIN CIRCUIT	CONTACTOR	M6	22
	OVERLOAD RELAY	M6	16.5
OPERATION CIRCUIT	CONTACTOR	M3.5	7.8
	OVERLOAD RELAY	M3.5	7.8

(Reference 43064009R01).

***REMARK**

- DIMENSION UNIT = Millimeter (mm.).
- (a) = AUX. CONTACT NORMALLY OPENED.
- (b) = AUX. CONTACT NORMALLY CLOSED.

DWN. S. CHAIAMPOL	09/08/16	PROJECTION	TITLE
CHKD. <i>Jan-a</i>	S	SCALE NTS.	DIMENSION OF SH80C-RT, RTK
APPD. <i>C.Kiattisak</i>			
HITACHI Hitachi Industrial Technology (Thailand), Ltd.			REV.
			4HTN000871

00
01
01