

HITACHI ELECTROMAGNETIC SWITCH

Type	Rated insulation voltage (Ui)	Max. rated capacity of motor			Rated thermal current (AC1 = Ith)	Applicable standard	Aux. Contact	Weight
		V	kW	A				
H100C-RT	AC 660	240V	30kW	105A	135	IEC 60947-4-1	(2a2b) x 2	6.4 kg
H100C-RTK		440V	50kW	100A				

*WITH AUX. CONTACT (3 a 3 b) x 2 = 243 mm.

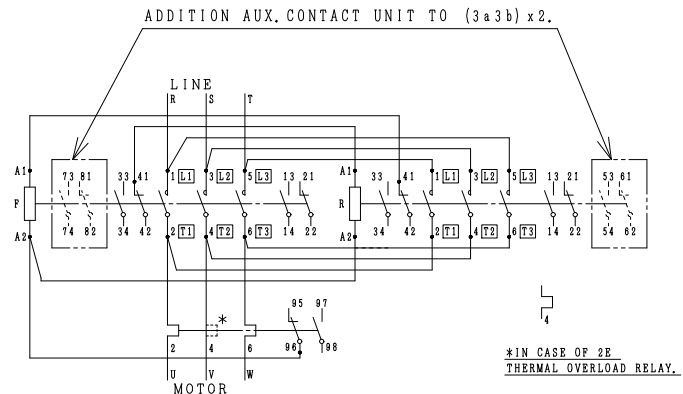
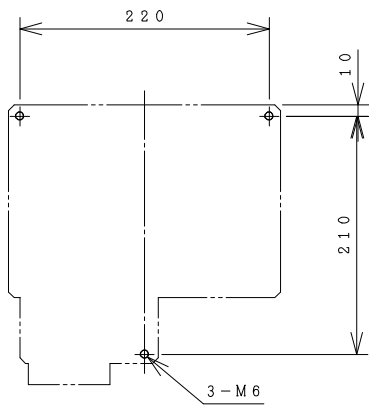
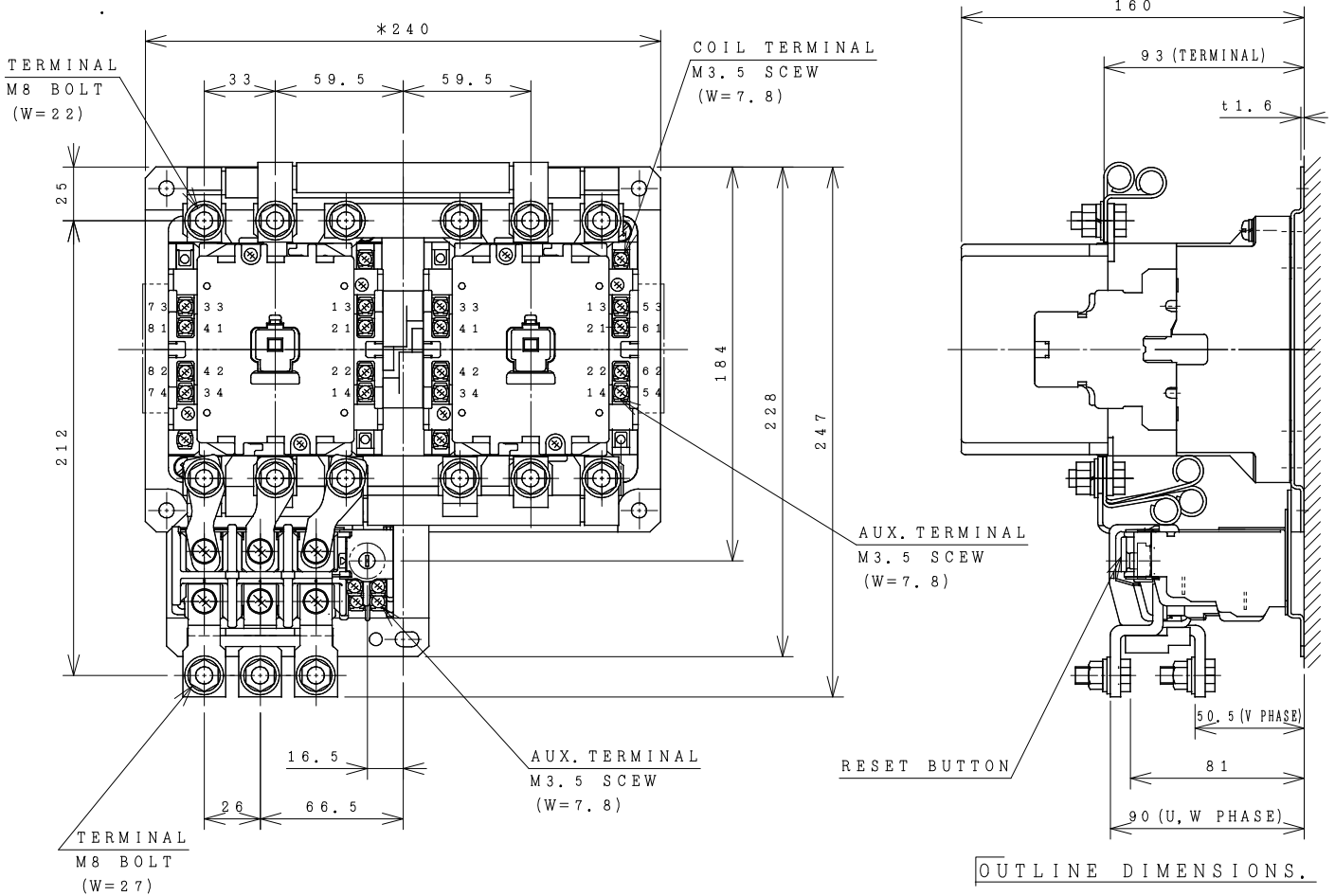

(Reference 43058179R01).

DWN. S. CHAIAMPOL	09/08/16	PROJECTION	TITLE
CHKD. <i>Jan-a</i>	S		DIMENSION OF H100C-RT, RTK
APPD. <i>C. Kiattisak</i>		SCALE NTS.	
HITT WORKS DWG. No.			REV.
HITACHI Hitachi Industrial Technology (Thailand), Ltd.			00
			01
4HTN000875			SH.
			01

(W=) : WIDTH OF TERMINAL.

*REMARK

- DIMENSION UNIT = Millimeter (mm.).

- (a) = AUX. CONTACT NORMALLY OPENED.

- (b) = AUX. CONTACT NORMALLY CLOSED.