

HITACHI ELECTROMAGNETIC SWITCH

Type	Rated insulation voltage (Ui)	Max. rated capacity of motor			Rated thermal current (AC1 = Ith)	Applicable standard	Aux. Contact	Weight
H200C-RT	AC 660 V	240V	55kW	182A	260 A	IEC 60947-4-1	(2a2b) x 2	18 kg
H200C-RTK		440V	90kW	180A				

*WITH AUX. CONTACT (3a3b) x 2 = 335 mm.

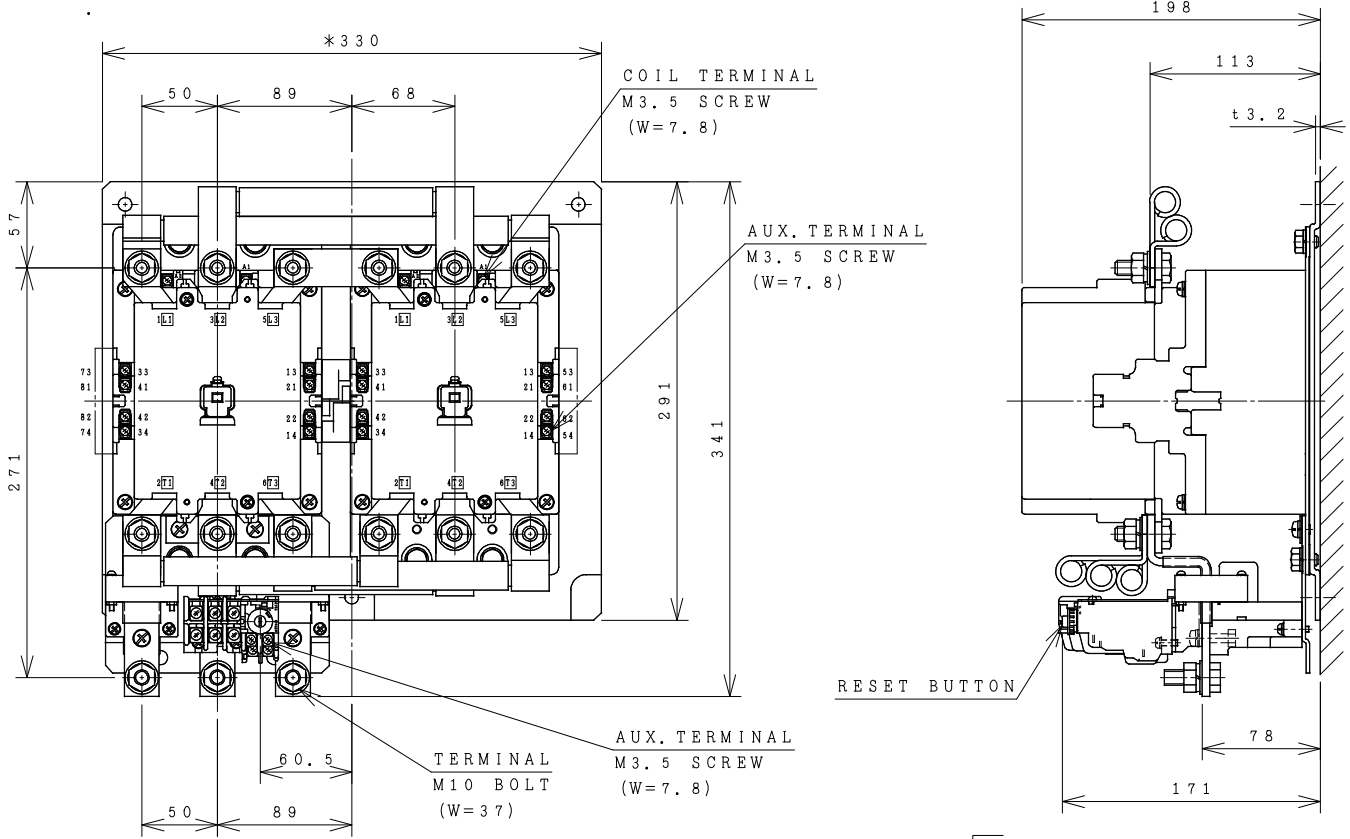

OUTLINE DIMENSIONS.

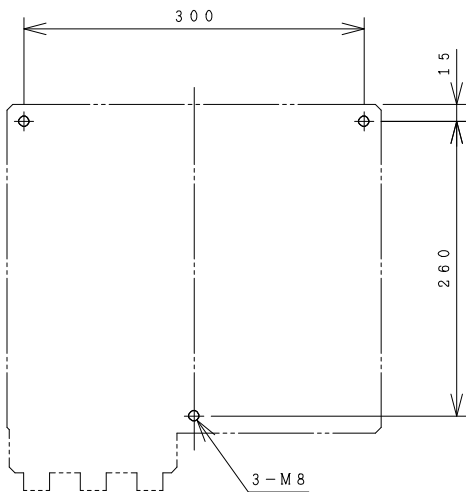

MOUNTING HOLES.

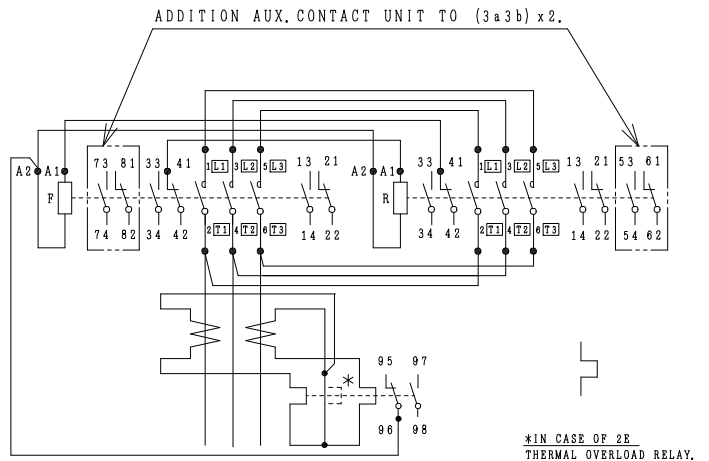

CONTACTS ARRANGEMENT.

(Reference 43062356R02).

(W=) : WIDTH OF TERMINAL.

*REMARK

- DIMENSION UNIT = Millimeter (mm.).
- (a) = AUX. CONTACT NORMALLY OPENED.
- (b) = AUX. CONTACT NORMALLY CLOSED.

DWN. S. CHAIAMPOL	26/08/16	PROJECTION	TITLE
CHKD. <i>jsm-a</i>	S		DIMENSION OF H200C-RT, RTK
APPD. <i>C.Kiattisak</i>		SCALE NTS.	
HITT WORKS DWG. No.			REV.
HITACHI Hitachi Industrial Technology (Thailand), Ltd.			00
			01
4HTN000904			01