

HITACHI ELECTROMAGNETIC CONTACTOR

Type	Rated insulation voltage (Ui)	Max. rated capacity of motor			Rated thermal current (AC1 = Ith)	Applicable standard	Aux. Contact	Weight
		240V	75kW	240A				
H250C	AC 660 V	240V	75kW	240A	300 A	IEC 60947-4-1	2a2b	5.5 kg
		440V	120kW	240A				

*WITH AUX. CONTACT 4a4b = 162 mm.

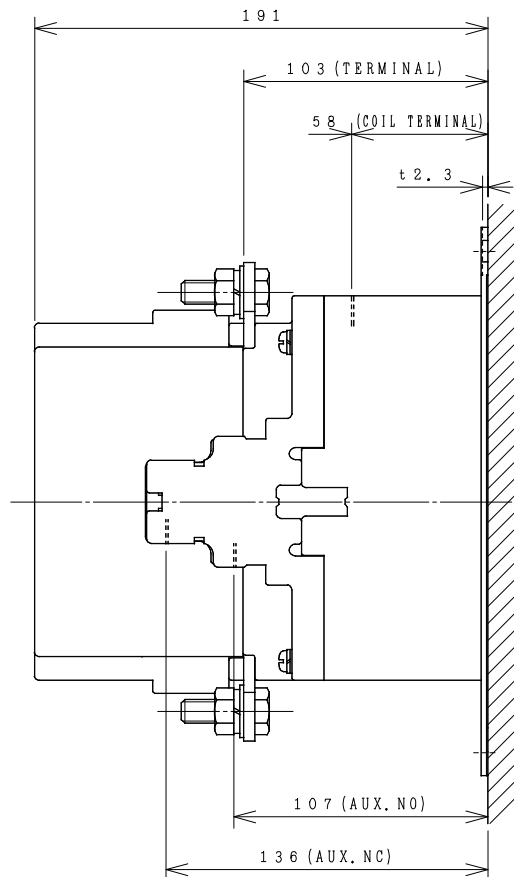
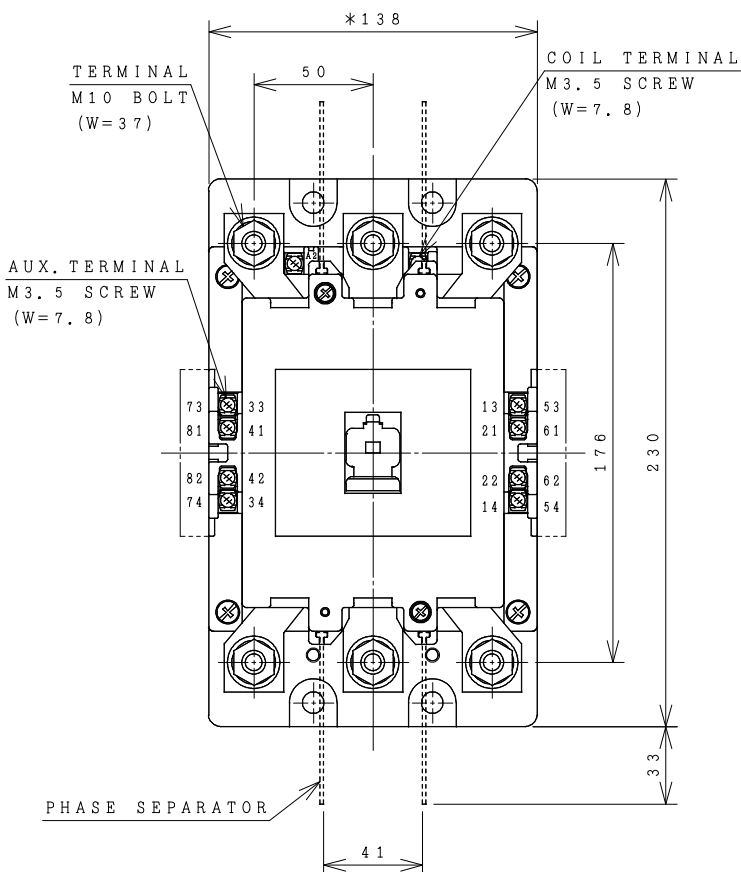

OUTLINE DIMENSIONS.

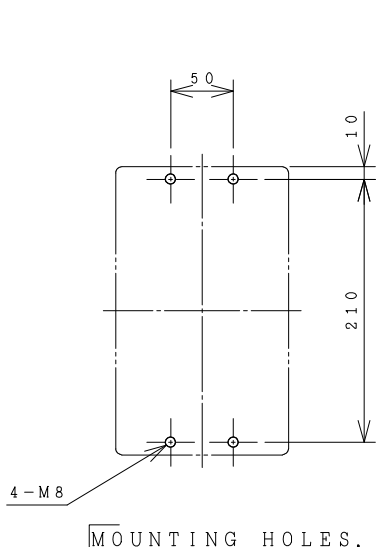

MOUNTING HOLES.

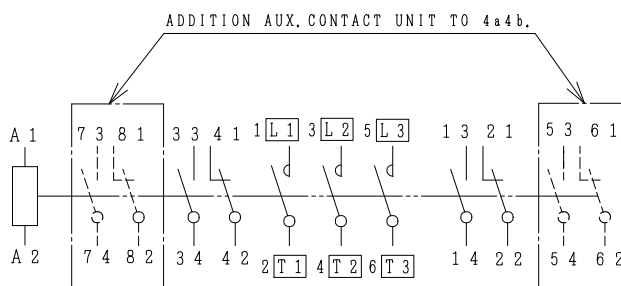

CONTACTS ARRANGEMENT.

(Reference 43055972R02).

***REMARK**

- DIMENSION UNIT = Millimeter (mm.).
- (a) = AUX. CONTACT NORMALLY OPENED.
- (b) = AUX. CONTACT NORMALLY CLOSED.

DWN. S. CHAIAMPOL	26/08/16	PROJECTION	TITLE
CHKD. <i>Jan-a</i>	S	SCALE NTS.	DIMENSION OF H250C
APPD. <i>C.Kiattisak</i>			
HITACHI Hitachi Industrial Technology (Thailand), Ltd.			4HTN000911
			REV.
			00
			SH.
			01
			01

(W=) : WIDTH OF TERMINAL.