

HITACHI ELECTROMAGNETIC CONTACTOR

Type	Rated insulation voltage (Ui)	Max. rated capacity of motor			Rated thermal current (AC1 = Ith)	Applicable standard	Aux. Contact	Weight
		240V	90kW	300A				
H300C-R	AC 660 V	240V	90kW	300A	350 A	IEC 60947-4-1	(3a3b) x 2	25 kg
		440V	150kW	300A				

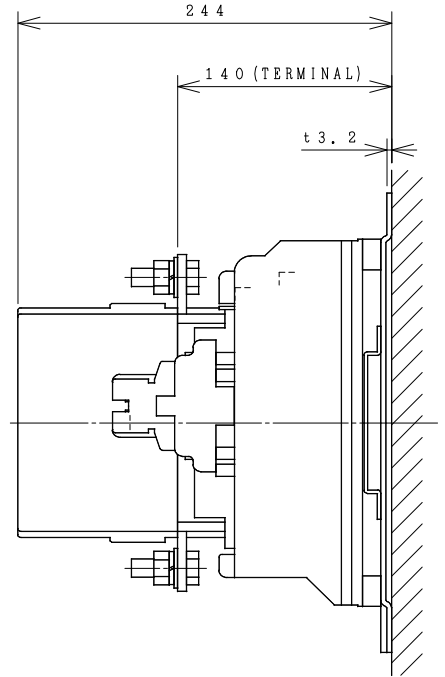

OUTLINE DIMENSIONS.

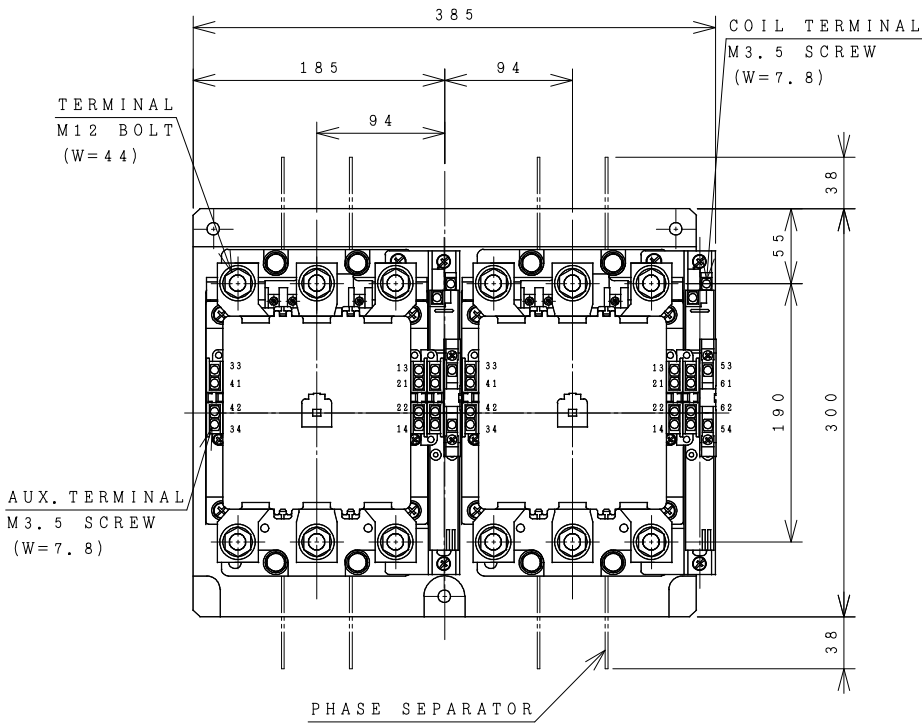
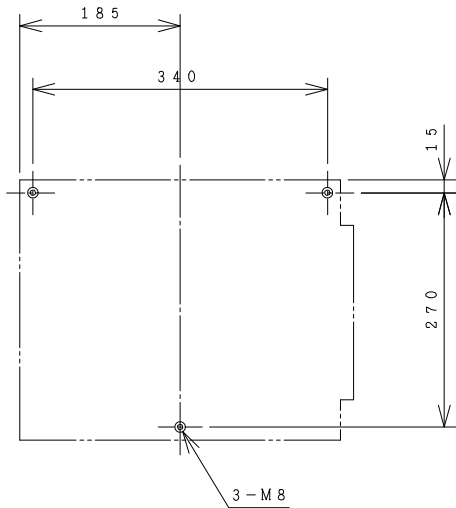

MOUNTING HOLES.

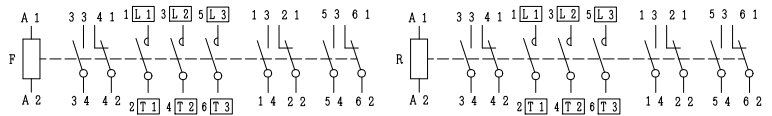

CONTACTS ARRANGEMENT.

(Reference 43056006R03).

REMARK

- DIMENSION UNIT = Millimeter (mm).
- (a) = AUX. CONTACT NORMALLY OPENED.
- (b) = AUX. CONTACT NORMALLY CLOSED.

DWN. S. CHAIAMPOL	26/08/16	PROJECTION	TITLE
CHKD. <i>Jan-a</i>	S	SCALE NTS.	DIMENSION OF H300C-R
APPD. <i>C. Kiattisak</i>			
HITACHI Hitachi Industrial Technology (Thailand), Ltd.			4HTN000922
			REV. 00 SH. 01 01

(W=) : WIDTH OF TERMINAL.